



MOM: An automated support tool for Railway Timetabling

<http://www.dsic.upv.es/grupos/gps/MOM/>

Over the last few years, access to railway infrastructures has been opened to new operators and, thus, railway traffic has increased considerably. This has created the need to optimize the use of high-traffic railway lines, which should be combined with quality service to the user and efficient, robust and highly reactive management.

Thanks to developments in computer science and advances in the fields of optimization and intelligent resource management, computed-aided systems can assist railway managers in obtaining an efficient use of railway infrastructures.

MOM is a flexible and useful tool for solving and obtaining optimized railways running maps (time-tables) in accordance with railway infrastructure, traffic and commercial requirements, and optimization criteria.

MOM obtains the required data from standard databases and obtains optimization parameters from friendly interfaces. Afterwards, it transforms the problem into mathematical models, applies several heuristic criteria and obtains optimized, robust and flexible railway timetables.

**Grupo de Inteligencia
Artificial, Planificación y
Scheduling
Univ. Politécnica de Valencia
46022 Valencia, Spain
www.dsic.upv.es/grupos/gps/**

**ADIF UN-Circulación
Estación de Chamartín
Agustín de Foxá, s/n
28036 Madrid,
Spain
www.adif.es**

MOM has been developed under an agreement between the Administrator of the Spanish Railway Network (ADIF) and the Technical University of Valencia (Spain).

© 2002-2008

Features

MOM is a computer-aided tool that automatically obtains optimized running maps with the following features:

- ❖ Optimization of journey times.
- ❖ Minimization of traffic operations and stop times.
- ❖ Prioritization of trains and balancing of delays.
- ❖ Robustness & fault-tolerant time-tables.

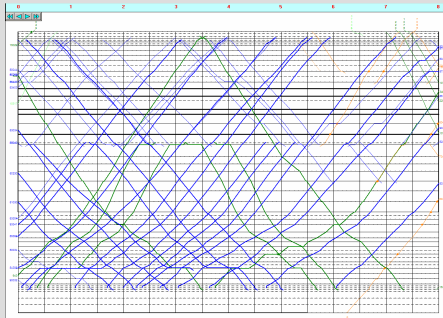

MOM obtains optimized railway timetables in seconds and it is able to deal with both hard and soft constraints. It integrates a feature that automatically adjusts or relax soft constraints (i.e.: traffic constraints, journey times, etc.) to significantly improve the running map. Relaxed constraints are provided to the user for validation.

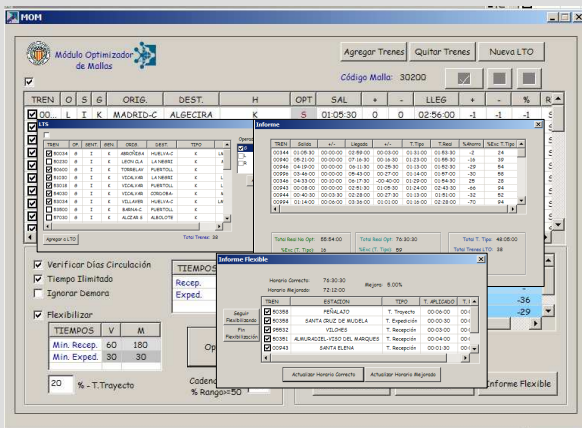

MOM is easily integrated

MOM obtains the required data directly from common databases (such as those used in railway companies).

Currently, MOM is fully used and integrated with the ADIF's host database and runs directly from the graphic-timetabling tool used in ADIF.

The user can determine which trains should be optimized and can determine the optimization parameters by means of a flexible interface. At the end of the optimization process, several reports are provided.

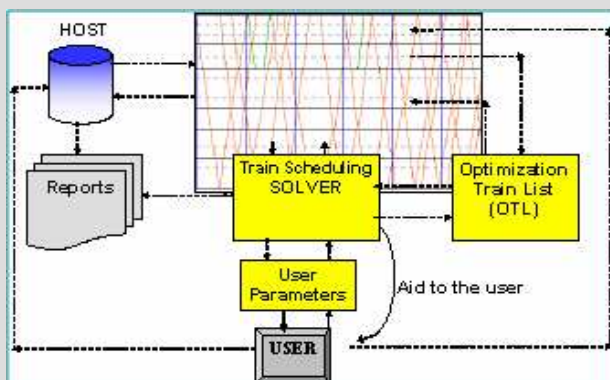

MOM takes into account:

Railway Infrastructure

- ❖ Tracks between dependencies (one/two way).
- ❖ Capacity of each station for traffic operations, type of trains that can be managed, station closing times, etc.
- ❖ Previously scheduled use of the railway infrastructure (trains already running).

Traffic Constraints

- ❖ Single & Double tracks.
- ❖ Crossing & overtaking operations.
- ❖ Headway times.
- ❖ Available tracks in Stations.

Journeys:

- ❖ Travel time between stations.
- ❖ Departure time at the initial station.
- ❖ Commercial Stops.
- ❖ Frequency.
- ❖ Circulation Days.

Model

MOM integrates mathematical models and integer programming, constraint satisfaction, and operation research, as well as intelligent and heuristic techniques.

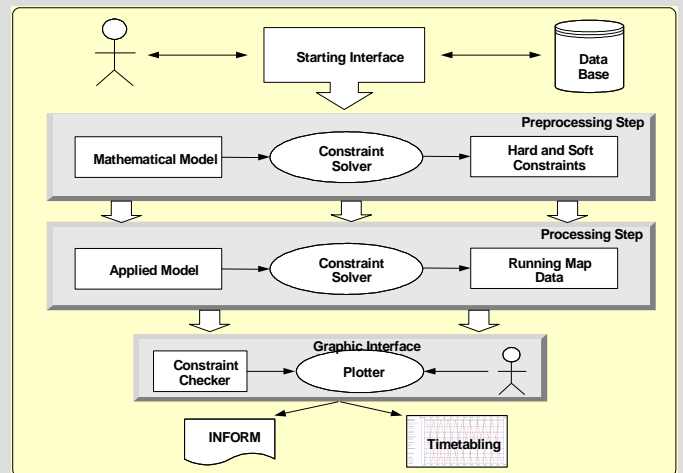

Benefits for Railway Management

MOM is a decision support system for the railway scheduling problem. It allows users to optimize the use and management of railway infrastructures by means of a flexible, powerful, integrated and user-friendly interface system.

The user can automatically obtain optimized timetables for periodic or non periodic trains according to existing and high-traffic railway infrastructures.

- ❖ MOM is **flexible** and friendly. It is able to deal with both hard and soft constraints.
- ❖ MOM can validate and perform **capacity & robustness analyses**.
- ❖ MOM can be easily **integrated** into already existing data-bases and other computer-aided tools for railway management.
- ❖ MOM can **reschedule** running maps according to incidences and delays in on-line real-traffic management.